

ZEN



WASH BASIN

PRODUCT ID
(RB.ZEN.01G108.01.08)

Vitreous China under counter Wash Basin without a tap platform. Designed with an overflow hole and a deep bowl for comfortable use.

FEATURES

- Vitreous China under counter wash basin
- Contemporary design
- Front overflow hole
- Deep bowl for comfortable use
- Fulfills high design and quality expectations

INCLUDED COMPONENTS

- Under counter wash basin fixing kit
- Overflow hole cover
- Faucets not included

WARRANTY

- 25 year written warranty against crazing and dunting

STANDARDS APPLICABLE

- Specified model meets or exceeds the following:
- BS 3402 : 1969
 - BS EN 14688 : 2006

TECHNICAL INFORMATION

** Approximate measurements for comparison only

CONFIGURATION	UNDER COUNTER WASH BASIN
Weight	10 kg
Basin Area	530 X 385 X 165 mm
Height - Floor to Rim	850 mm
Nominal Dimensions	585 X 435 X 215 mm
Waste Hole	45 mm
Water Depth	125 mm

ZEN WASH BASIN

TECHNICAL DRAWINGS

All drawings contain the necessary measurements, which are subject to standard tolerances. They are stated in mm, are drawn on a scale of 1:20 and are non-binding. Exact measurements, in particular for customized installation scenarios, can only be taken from the finished ceramic piece.

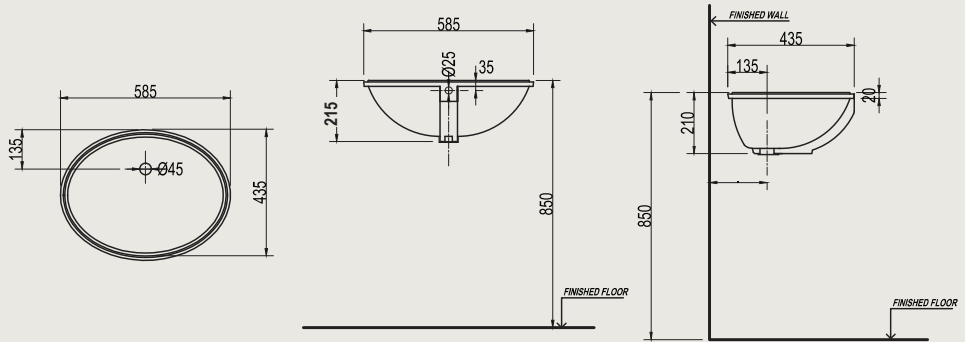

INSTALLATION NOTES

- Install this product according to the installation guide
- Scan for instructions



Royal Ceramics Lanka PLC.

No.20, R.A. De Mel Mawatha, Colombo 03, Sri Lanka.

☎ 076 6 223 344 ✉ info@rcl.lk 🌐 www.rocell.com

FOLLOW US



** Dimensions of fixtures are nominal and may vary within the range of tolerance. These measurements are subject to change or cancellation. No responsibility is assumed for use of superseded or voided leaflet.